

DATA SHEET

Miniature Fiber Optic 3G-SDI Digital Video Extension Modules For HDCCTV

Contents

- ◆ Description
- ◆ Features
- ◆ Applications
- ◆ Technical Specifications
- ◆ Drawing
- ◆ Cable Connection
- ◆ Environmental Reliability Test
- ◆ Terminology

Optolinks

HQ Address
46 Corporate Park #130 Irvine, CA 92606
949-701-4742
info@VigilLink.com

Fiber Optic 3G-SDI Extension Module

Description

OPTICIS miniature 3G-SDI extender is an optimized and high-end level solution designed for transmission of multi-rate digital video including 3G-SDI, HD-SDI and SD-SDI over one (1) ST single-mode fiber-optic cable. Supporting the new 1080p, 3G-SDI format, it converts and transmits one (1) channel of 3G-SDI (SMPTE-424M), HD-SDI (SMPTE-292M) or SD / ED-SDI (SMPTE-259M/344M) serial digital video signal perfectly over long distance right after its transmitter receive the input signal. It adopts ST terminated fiber-optic connector and 75Ohm HD-SDI BNC input connector for wide range of application.

Due to the use of advanced digital fiber optic transmission technology, no user adjustments are required in the Mini 3G-SDI extender system, enabling quick setup and trouble-free operation. It comes with a miniature metal die-casting enclosure for harsh applications including security, staging, medical, military and more for your world.

The modules are consisted of two (2) parts as follows;

- One transmitter converting digital video signal to optical signals, model name: SDISE-100-T
- One receiver converting optical signals to digital video signals, model name: SDISE-100-R

The package includes as follows;

- One (1) pair of transmitter and receiver
- Two (2) DC +5V / 1A Adaptors
- User manual

Features

- ◆ Supports multi-rate SDI up to 3G-SDI (SMPTE-424M).
- ◆ Extends up to 2km @3Gbps.
- ◆ Transmits multi-rate SDI digital video over one (1) fiber.
- ◆ DC 5V 1A input
- ◆ Wide range of operating temperature: -20 ~ 70 °C
- ◆ HD-SDI BNC input connector and ST terminated fiber optical connector.
- ◆ Robust metal die-casting enclosure for harsh environment.

Applications

- ◆ Security systems installing remote HDCCTV camera to DVR or monitoring room using 3G-SDI digital video extension.
- ◆ Fiber optic applications with free-interference using 3G-SDI signals including staging, medical, military, government and security purposes.

Technical Specifications

- General Specifications

	Parameter	Specifications
Components	Laser Diodes in TX Module	1310 FP laser diode
	Photo Diodes in RX Module	InGaAs/InP PIN photo diode
Electrical	Input and Output Signals	SMPTE 424M/292M/259M
	Data Transfer Rate (Graphic Data)	Max. 3Gbps
	Total Jitter at the end of Rx output	Max. 0.3UI
	Propagation Delay	Max. 40ns
Optical	Link Power Budget	Min 11dB
Connect	Optical Connector	ST Connector
	Electric Connector Type from Modules	75Ohm BNC (Male)
	Recommended Fiber	Standard single-mode fiber

- Absolute Maximum Ratings

Parameter	Symbol	Minimum	Maximum	Units
Supply Voltage	V _{CC}	+4.5	+5.5	V
Operating Temperature	T _{op}	-20	70	°C
Storage Temperature	T _{sto}	- 30	+ 85	°C
Storage Relative Humidity	RH _{sto}	0	95	%RH

- **Operating Conditions**
Transmitter module (E-to-O converter) : SDISE-100-T

	Parameter	Symbol	Minimum	Typical	Maximum	Units
Power Supply	Supply Voltage	V _{CC}	4.5	5	5.5	V
	Supply Current	I _{TCC}	-	220	-	mA
	Power Dissipation	P _{TX}	-	1.1	-	W
	Power Supply Rejection (Note1)	PSR	-	50	-	mV _{p-p}
Electrical Link	Input Signal		SMPTE 424M/292M/259M			mV _{p-p}
	Input Impedance	Z _{IN}	-	75	-	Ω
	Input Signal Level		720	800	880	mV _{p-p}
	Return Loss		10	-	-	dB
	Propagation Delay		-	-	1.5	ns
	Data rate		-	-	3	Gbps
Optical Link	Output Optical Power	P _o	-9	-	-4	dBm
	Wavelength	λ	1290	1310	1330	nm
	Spectral width in RMS	Δλ	-	-	5	nm
	Extinction Ratio	Ext	-	7	-	dB
	Rising Time (Note2)	T _{rise}	-	200	-	ps
	Falling Time (Note2)	T _{fall}	-	200	-	ps
	Jitter in p-p value	T _{jitter}	-	80	-	ps

Note1. Tested with a 50mV_{p-p} sinusoidal signal in the frequency range from 500 Hz to 500 MHz on the V_{CC} supply with the recommended power supply filter in place. Typically less than a 0.25 dB change in sensitivity is experienced.

Note2. 20% - 80%; Measured unfiltered @ 3Gbps

Receiver module (O-to-E converter): SDISE-100-R

	Parameter	Symbol	Minimum	Typical	Maximum	Units
Power Supply	Supply Voltage	V _{CC}	4.5	5	5.5	V
	Supply Current	I _{TCC}	-	160	-	mA
	Power Dissipation	P _{TX}	-	0.8	-	W
	Power Supply Rejection (Note1)	PSR	-	50	-	mV _{p-p}
Electrical Link	Output Signal		SMPTE 424M/292M/259M			mV _{p-p}
	Output Impedance	Z _{IN}	-	75	-	Ω
	Output Signal Level		720	800	880	mV _{p-p}
	Return Loss		10	-	-	dB
	Propagation Delay		-	-	40	ns
	Data rate		-	-	3	Gbps
	Total Jitter	TR _{jitter}	-	0.2	0.3	UI
Optical Link	Receiving Optical Power	P _o	-20	-	0	dBm
	Wavelength	λ	1100	1310	1650	nm
	Power Budget	P _{bgt}	-	12	-	dB

- Recommended Specifications of Fibre-Optic Cables

Parameters	Conditions	Specifications
Fibre Type	Glass single-mode Fiber	9.5 ± / 125 ± 2 μm
Modal Bandwidth	λ = 1310nm, 1550nm	Min. 400 MHz km
Fiber Cable Attenuation	λ = 1310nm, 1550nm	>0.3dB/km
No. of Ferrules	ST Connector	1 ferrules
Skew	-	2%
Insertion Attenuation	-	1.6%
Total Optical Attenuation	-	30mm

Drawing of Modules

Dimension [mm]

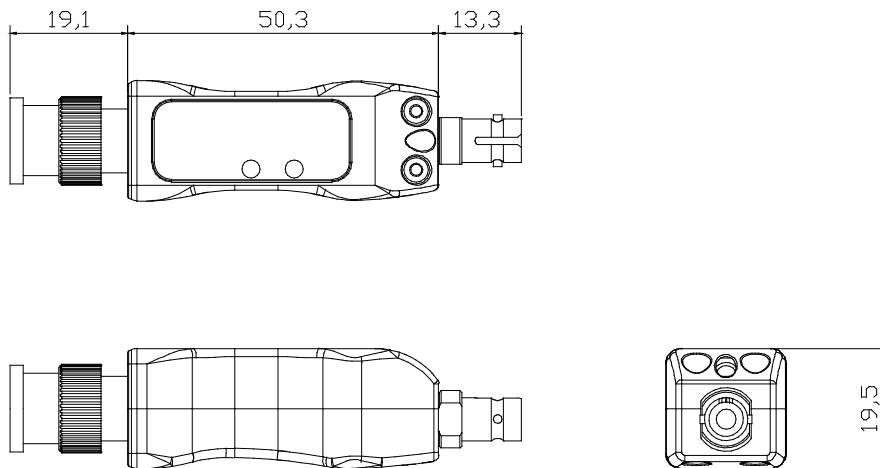

Note: The transmitter, SDISE-100-T and the receiver, SDISE-100-R have the same mechanical dimensions.

Drawing of Cable Connections

The diagram shows the connection of transmitter (Tx; Connect to SDI source like a HDCCTV camera) and receiver (Rx; Connect to SDI display) modules by using one (1) ST patch cord fiber.

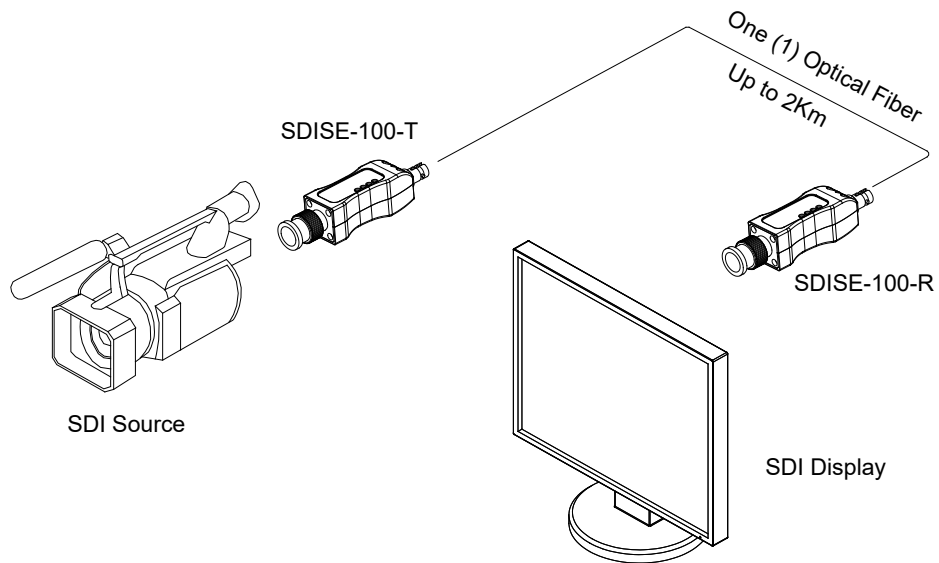

EMC Test Data

1) EMI: Meet FCC class A (ICES-003) and CE class A

STANDARDS		CONDITIONS
EN 55 022 (CISPR22) FCC; PART 15 SUBPART B	CE (Conducted Emission) & RE (Radiated Emission)	Meet Class A
EN 61000-3-2 (IEC 61000-3-2)	Harmonics	Meet Class A
EN 61000-3-3 (IEC 61000-3-3)	Flickers	Meet Class A

2) EMS: Meet CE standards (EN 55024) and CISPR24 equivalents

STANDARDS		CONDITIONS
EN 61 000-4-2:1995	Electrostatic Discharge Immunity (Air: 8kv, Contact: 4kv)	Meet Criterion B
EN 61 000-4-3:1996	Radiated RF E-Field (80~1000 MHz) 3V/m (AM 80%, 1kHz)	Meet Criterion A
EN 61 000-4-4:1995	Fast Transients (5kHz, 60Seconds)	Meet Criterion B
EN 61 000-4-5:1995	Surge Transients	Meet Criterion B
EN 61 000-4-6:1996	Conducted Susceptibility (CS) Radiated Susceptibility (RS)	Meet Criterion A
EN 61 000-4-11:1994	Voltage Dips, Interruption & Variation	Meet Criterion C

Terminology

- SDI Serial Digital Interface referring to a family of video interfaces standardized by SMPTE.
- SMPTE The Society of Motion Picture and Television Engineers or SMPTE, founded in 1916 as the Society of Motion Picture Engineers or SMPE, is an international professional association, based in the United States of America.
- SMPTE-424M Standard published by SMPTE expanding upon SMPTE-259M, SMPTE-344M, and SMPTE-292M allowing for bit-rates of 2.970Gbit/s and 2.970/1.001Gbit/s over a single-link coaxial cable. These bit-rates are sufficient for 1080p video at 50 or 60 frames per second. The signal formats carried over SMPTE-424M are specified in SMPTE-425M.
- SMPTE-344M Standard published by SMPTE which expands upon SMPTE-259M allowing for bit-rates of 540 Mbit/s, allowing EDTV resolutions of 480p and 576p. This standard is part of a family of standards that define a Serial Digital Interface.
- EMI Electro Magnetic Interference.
- EMS Electro Magnetic Susceptibility.
- RFI Radio Frequency Interference.